

Repairhints

8310

NHM-7



GENERAL

-about Phoenix

When changing the phone mode with Phoenix, note that it is not possible to activate local mode directly from normal mode – change to test mode first! In normal mode the phone works as it would be supplied by the normal phone battery. In local mode the watchdog is disabled while in test mode only MCU-software is working without loading the PPM-file.

Using JBV-1 it is possible to change to local mode by supplying JBV-1 with +12VDC. If JBV-1 is supplied with +4VDC you have to change the phone mode manually with Phoenix.

When using service jig MJS-46 take care not to supply more than +12VDC – the jig will surely be damaged!

-Component characteristics

Some components contain important data.

Several described steps are only practicable if you are able to reflash/ realign the phone and/or rewrite IMEI/SIMlock in certain cases. Please pay attention to separate notes.

-Broken balls, μ BGA

All replaceable μ BGA-components must be renewed after removing. Reflow with hot air fan is not allowed!

Check soldering points, remove oxidated solderings (broken balls) carefully by enclosing few new solder before placing new components.

μ BGA must be soldered only with NMP approved μ BGA-rework machines (e.g. Zevac/OK International).

Only use recommended Fluxtype and an appropriate amount of it.

-PCB handling & cleaning

To avoid damages of PCB and/or components through electrostatic discharging, handle the module in ESD-suitable cases only. Always wear ESD-bracelets, which must be connected to earth bonding point.

Don't make any loose wiring connections or do some other unqualified rework anywhere.

For cleaning use appropriate materials only, do not use scratching or rubbing tools.

Because of organic surface protection (OSP), cleaning must only be done with a lint-free cloth which may be moisten with DI-water. IPA or other solvent like ethanol should only be used to clean gold pads for spring contacts without affecting the surrounding copper layers.

-Realign after repair

Characteristics of replacement parts are different.

To prevent additional faults after repair (eg. low standby time, loosing network etc.) it is necessary to retune phone values after repair.

INTRODUCTION

IMPORTANT:

This document is intended for use by authorized NOKIA service centers only.

The purpose of this document is to provide some further service information for NOKIA 8310 phones.

It contains a lot of collected tips and hints to find failures and repair solutions easily.

It also will give support to the inexperienced technicians.

Saving process time and improving the repair quality is the aim of using this document.

We have built it up based on fault symptoms (listed in "Contents") followed by detailed description for further analysis.

It is to be used additionally to the service manual and other service information like Service Bulletins. For that reason it does not contain any circuit descriptions or schematics.

All measurements are made using following equipment:

Nokia repair SW	: Phoenix version 03.40.00
Data package	: Version 4.0
Digital multimeter	: Fluke 73
Oscilloscope	: Hitachi V-1565; Fluke PM 3380A/B
Spectrum Analyzer	: Advantest R3162 with an analogue probe
RF-Generator /	: Rohde & Schwarz CMU 200
GSM Tester	

While every endeavour has been made to ensure the accuracy of this document, some errors may exist. If any errors are found by the reader, NOKIA should be notified in writing, using following procedure:

Please state:

Title of the Document + Issue Number/Date of publication.

Page(s) and/or Figure(s) in error.

Please send to:

Nokia GmbH
Service & Competence Center Europe
Meesmannstr.103
D-44807 Bochum / Germany
Email: training.sace@nokia.com

Copyright © Nokia Mobile Phones.

This material, including documentation and any related computer programs, is protected by copyright, controlled by Nokia Mobile Phones. All rights are reserved. Copying, including reproducing, modifying, storing, adapting or translating, any or all of this material requires the prior written consent of Nokia Mobile Phones. This material also contains confidential information, which may not be disclosed to others without the prior written consent of Nokia Mobile Phones.

Contents

PREFACE		2
	General	2
	Introduction	3
CHAPTER 1	PHONE DOES NOT SWITCH ON	5
CHAPTER 2	PHONE SWITCHES ITSELF OFF	7
CHAPTER 3	FLASH UPDATE NOT POSSIBLE	8
CHAPTER 4	SIMCARD FAULTS	9
CHAPTER 5	AUDIO FAULTS	10
CHAPTER 6	CHARGING FAULTS	11
CHAPTER 7	USER INTERFACE FAULTS	12
CHAPTER 8	NO SERVICE	13
CHAPTER 9	RX DOES NOT WORK	16
CHANGE HISTORY		18

CHAPTER 1 PHONE DOES NOT SWITCH ON

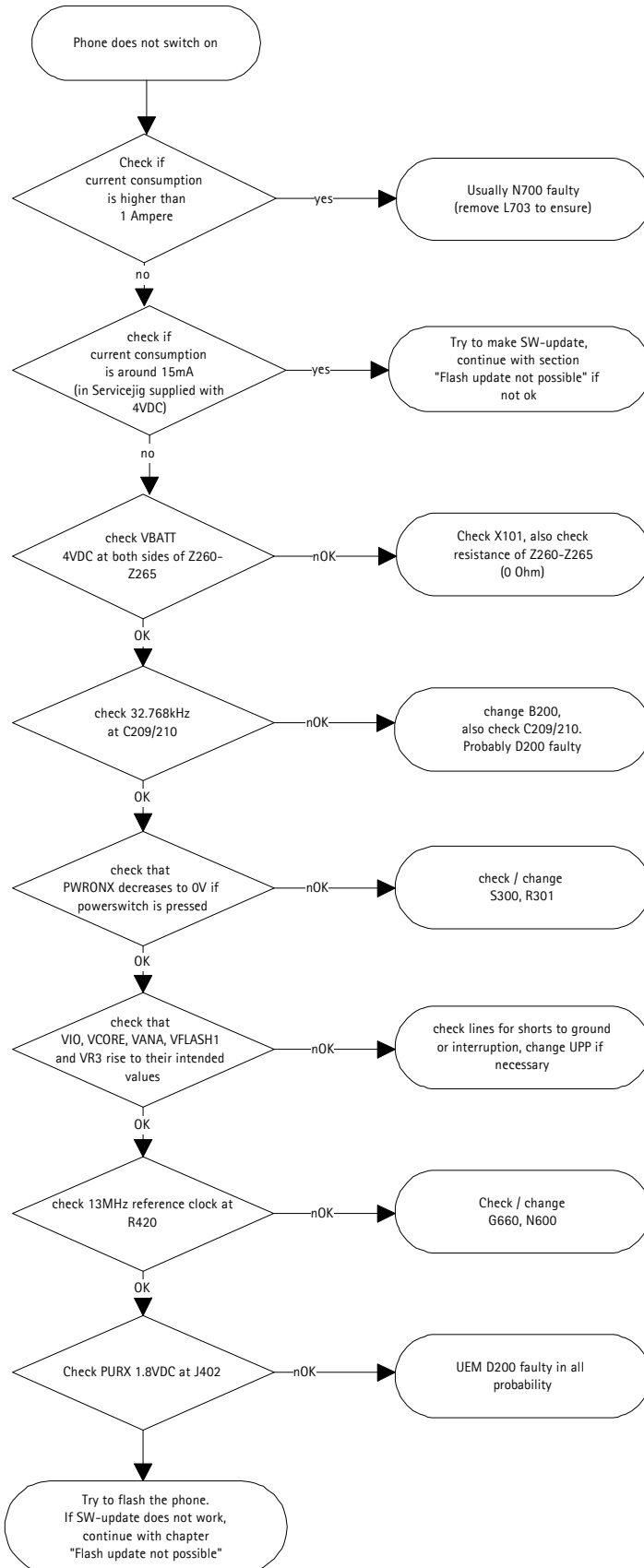

PHONE DOES NOT SWITCH ON**X101**

- check mechanical appearance of battery connector. Change part if it is bent, soiled or corroded.

S300

- check mechanical appearance of powerswitch, change if necessary.
- check voltage at S300, 3.8VDC in case that switch is not pressed. If voltage is not measureable or too low especially check R301 and C312.
- if switch is pressed, voltage at S300 must decrease to 0V. Change switch if necessary.

B200

- check DC-voltages at C209 and C210, normally 0.5VDC. If voltages are not ok check C209/210 for shorts to ground. It also is possible that UEM D200 is defect.
- if DC-voltages are ok but no 32.768kHz signal is measurable at C209/210 change the crystal B200.
Note that this signal must be always measurable if battery voltage is higher than 3.1VDC, even if phone is switched off! In this case amplitude of 32.768kHz is a bit lower (700mVpp at C209, 550mVpp at C210).

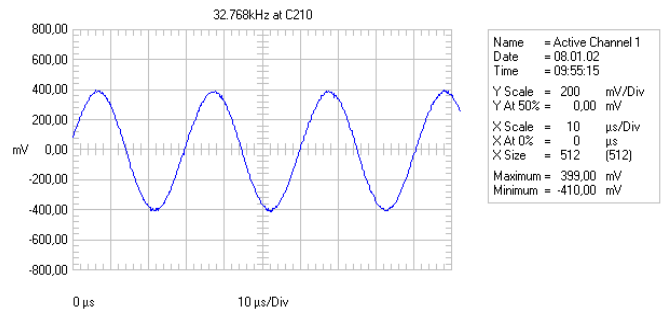
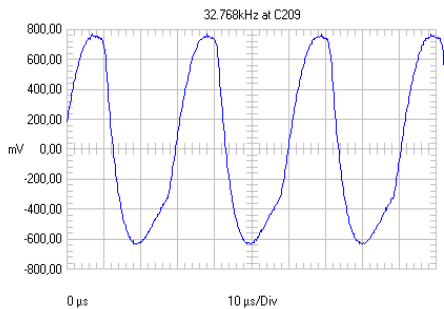
**D200**

- at this time it is not useful to change this part. IMEI and Simlockdata must be reconstructed in case that UEM has been changed. This is not possible up to now, but it is planned to make this possible in the future.

D450

- in case that phone does not switch on while current consumption stays on 15mA (in Service jig supplied with 4VDC) this indicates that Flash D450 probably is empty. Try to make SW-update. If any failuremessage appears during flashing, try SW-update a second time. It also can be necessary to change D450. Note that in this case you have to rewrite IMEI, Simlock data and Product code, furthermore you have to run all RX/TX-tunings and energy management calibration!

G660

- check voltage at C662, 2.8VDC
- check signal of 26MHz reference oscillator at C660:

With the voltage of 2.8VDC at C662 the oscillator must be able to work on a frequency around 26MHz, else you have to change G660.

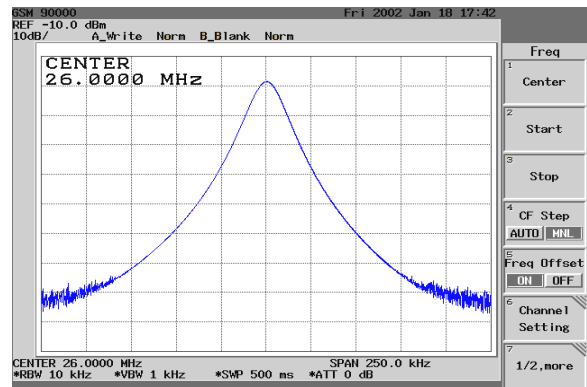
**N700**

- in case you suppose a defect poweramplifier N700 to be responsible for the fault, first of all check the current consumption of the phone. If current rises to more than 1 Ampere directly after connecting the phone to the servicebattery, remove coil L703 and check current consumption again. If current is ok now you have to change poweramplifier N700 with help of μBGA soldering machine and LGA rework kit LRK-1.

CHAPTER 2 PHONE SWITCHES OFF ITSELF

If this fault appears ensure that switching-off symptom is not the result of a too old phone software-version. SW-version should be 4.04 or newer!

Also check that symptom is not caused by an insufficient charged battery. In case of doubt retest the phone with a new or well charged battery. If this does not solve the problem, check the following:

- check mechanical appearance of battery connector X101. Change part if spring contacts are bent, soiled or corroded.
- check amplitude and frequency of 32.768kHz sleepclock-signal at J404, 1.9Vpp:

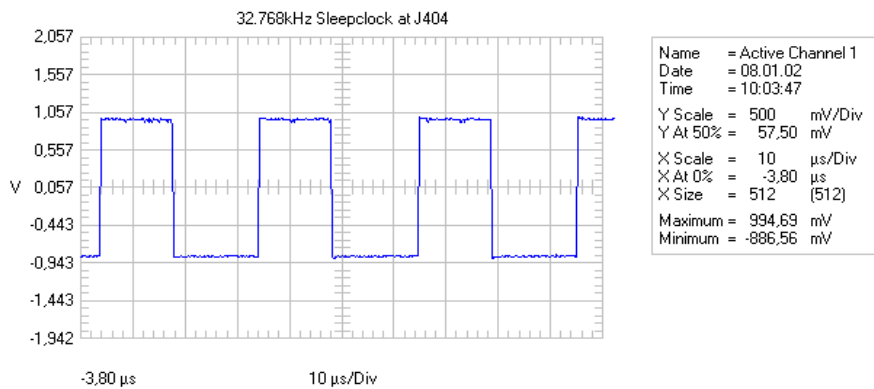

- check amplitude and frequency of 13MHz system clock at R420, 320mVpp:

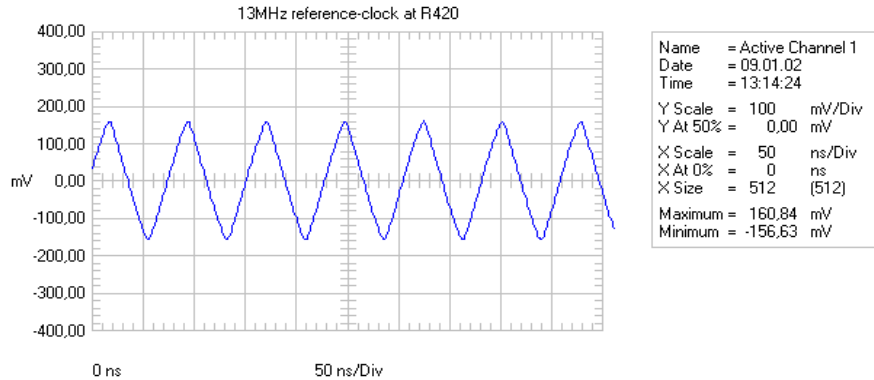

- try to calibrate TX-powerlevels. It is possible that poweramplifier N700 is defect so that the phone switches off if you try to tune the upper powerlevels because of too high current consumption.
- check solderings and resistance of R102 (100kΩ). It has been observed that solderings of this part were responsible for this fault in some cases, especially if phone switches off or resets after some minutes to some hours.

In case that phone switches off itself repeatedly after 30 seconds, this could be the result of a changed Flash D450 or UEM D200. Because of the data mismatch between both parts the watchdog will not be reset and the phone switches off itself.

CHAPTER 3 FLASH UPDATE NOT POSSIBLE

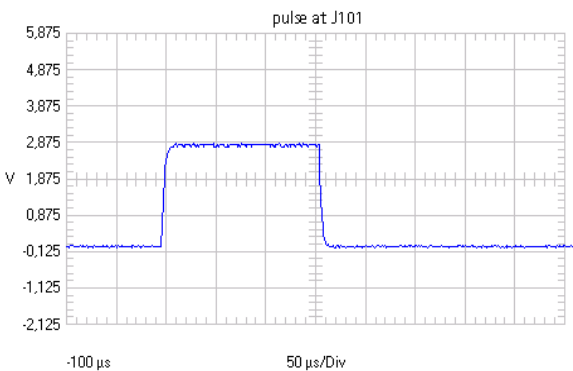
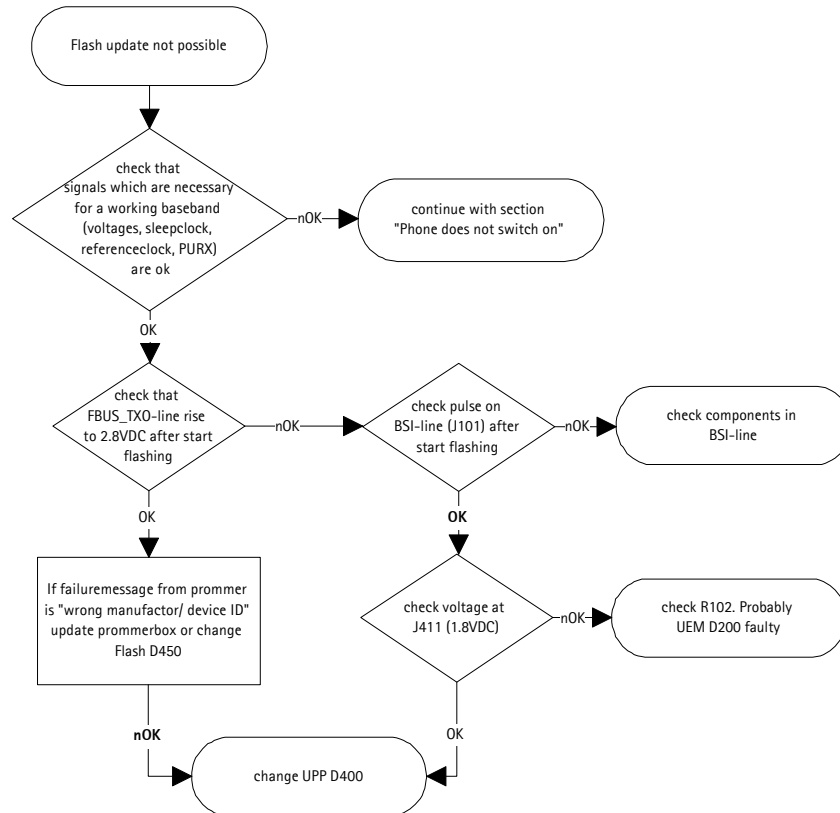

Name	= Active Channel 1
Date	= 18.01.02
Time	= 13:41:28
Y Scale	= 1 V/Div
Y At 50%	= 1.875 V
X Scale	= 50 μs/Div
X At 0%	= -100 μs
X Size	= 512 [512]
Maximum	= 2.845 V
Minimum	= -35.0 mV

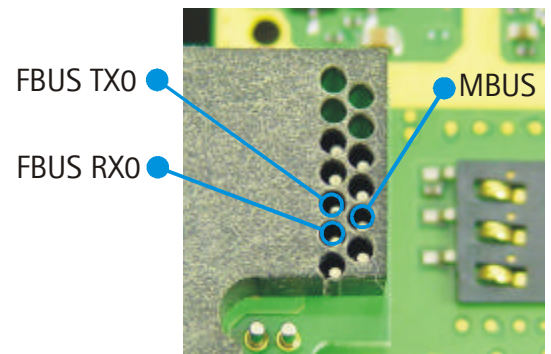

D200

- because of the missing possibility to rewrite phonedata after changing UEM D200 you should not change this part

D400

- if it was necessary to change UPP D400 you have to make SW-update after reworking this part. Otherwise the phone will not switch on!

D450

- change Flash D450 in case that prommer box messages "wrong manufactor/ devide ID". Note that after changing D450 you have to flash the phone, rewrite IMEI, Simlock data and Product code. Furthermore you have to run all RX/TX-tunings and energy management calibration!

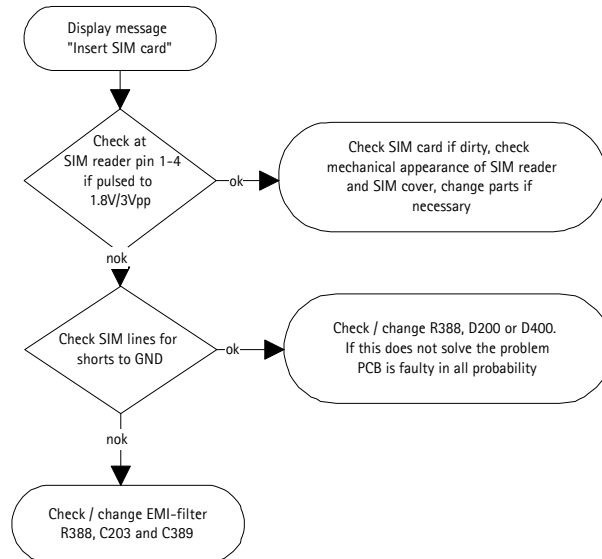
CHAPTER 4 SIMCARD-FAULTS**X386**

In case that phone messages "Insert SIM card" on LCD, first of all check mechanical appearance of SIM card reader X386. If contact springs are bent, soiled or corroded you have to change the sim reader.

R388/D200/D400

If mechanical appearance of SIM reader seems to be ok but fault persists, check with an oscilloscope if SIM lines at SIM reader pin 1-4 are pulse to 1.8Vpp / 3Vpp as shown in the chart below. Signals are slightly different between pin 1-4 but the amplitude always is 1.8Vpp / 3Vpp.

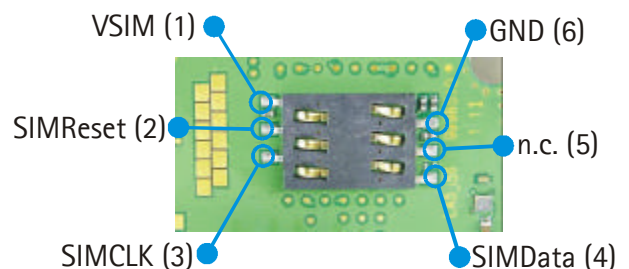
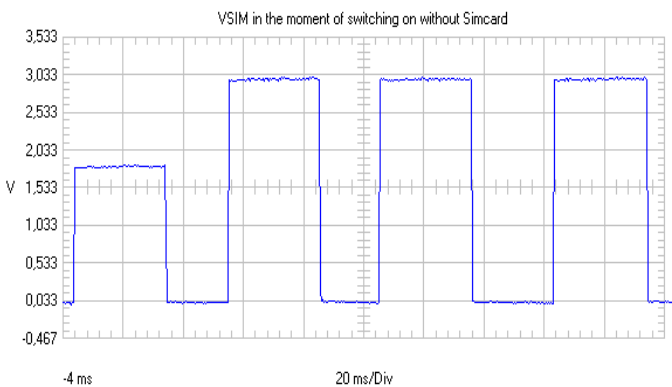

In case that the above mentioned signal is not measurable at one or more simlines, check SIM lines for shorts to ground. Resistance of simdata- and VSIMline normally is > 200kΩ, resistance of SIM reset- and SIM clock line normally is ~ 4.5MΩ. If resistance of any line is not ok check parts the SIM lines consists of (R388, C203, C389).

In case that resistance of all lines is ok but fault persists, EMI-filter R388 may have internal interruption. Change part and retest the phone. It also is possible that UEM D200 or UPP D400 are responsible for this fault. Due to the missing possibility to rewrite phonedata after changing UEM D200 you should not change this part.

CHAPTER 5 AUDIO-FAULTS

In case of any audiofault in the phone, the best way to define the fault is to make a call with the defect phone to a proper working one. In case that you can hear the speech of the proper working phone in the defect one but the other way round the speech of the defect phone is not audible in the proper working phone you know that the internal microphones signalpath is responsible for the fault. Of course you can use the same procedure to check the external audiopathes XMIC and XEAR.

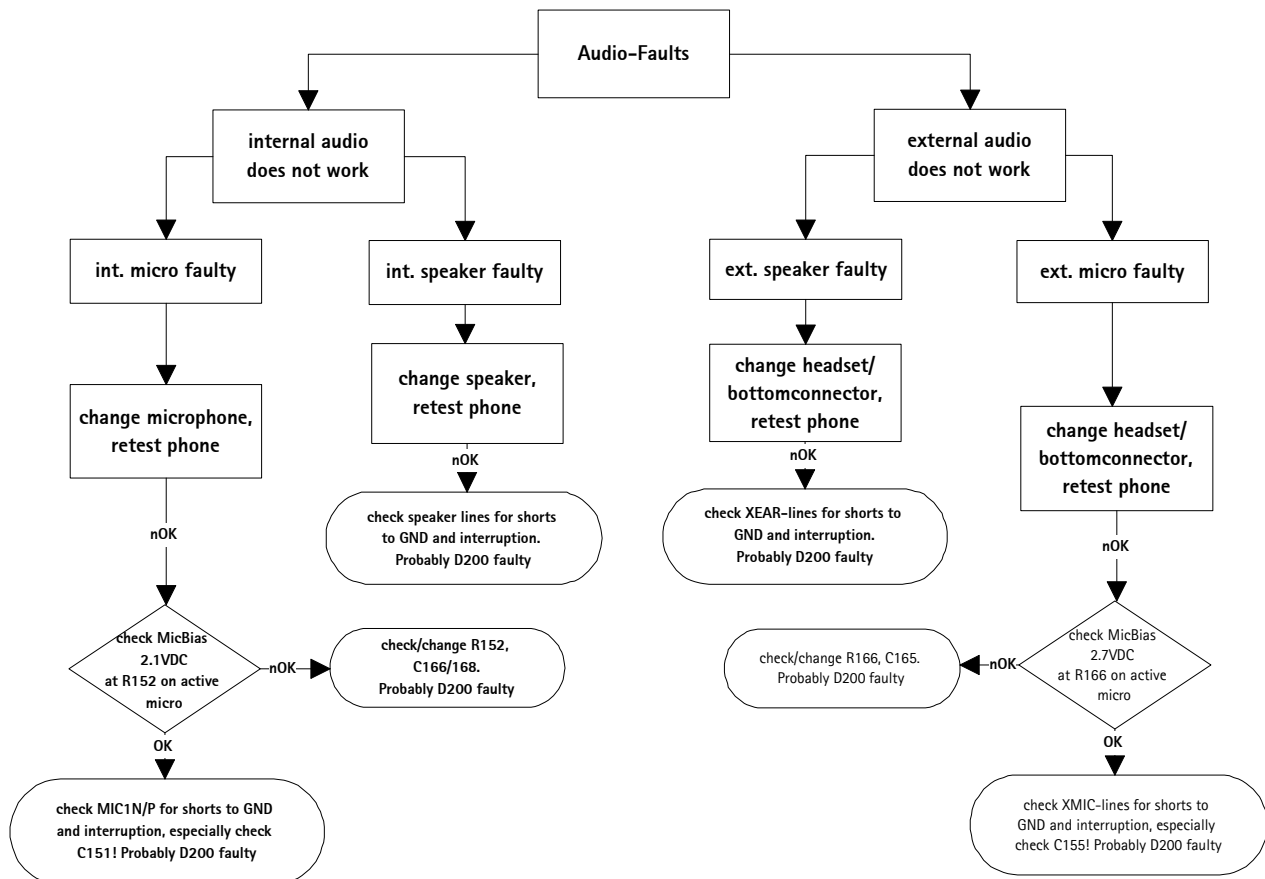

I009 bottomconnector

- check mechanical appearance of bottomconnector I009 in case that internal microphone does not work, external audiopath seems to be interrupted or headset is not recognized. Retest phone with new connector in case of doubt. Also ensure that contact pads for connector on PCB are clean.

I005 speaker

- check mechanical appearance of speaker. Change part if spring contacts are bent or soiled. Resistance of speaker normally is 30Ω. Also ensure that contact pads on PCB are clean.

C151/C155

- check resistance of the double capacitors, which normally is > 20MΩ. Both parts have tendencies to leak and often are responsible for missing uplink audio (C151 in case of internal -, C155 in case of external audio faults).

D200

- due to the missing possibility of rewriting IMEI and Simlock data after changing UEM D200 it is not useful to change this part at the moment.

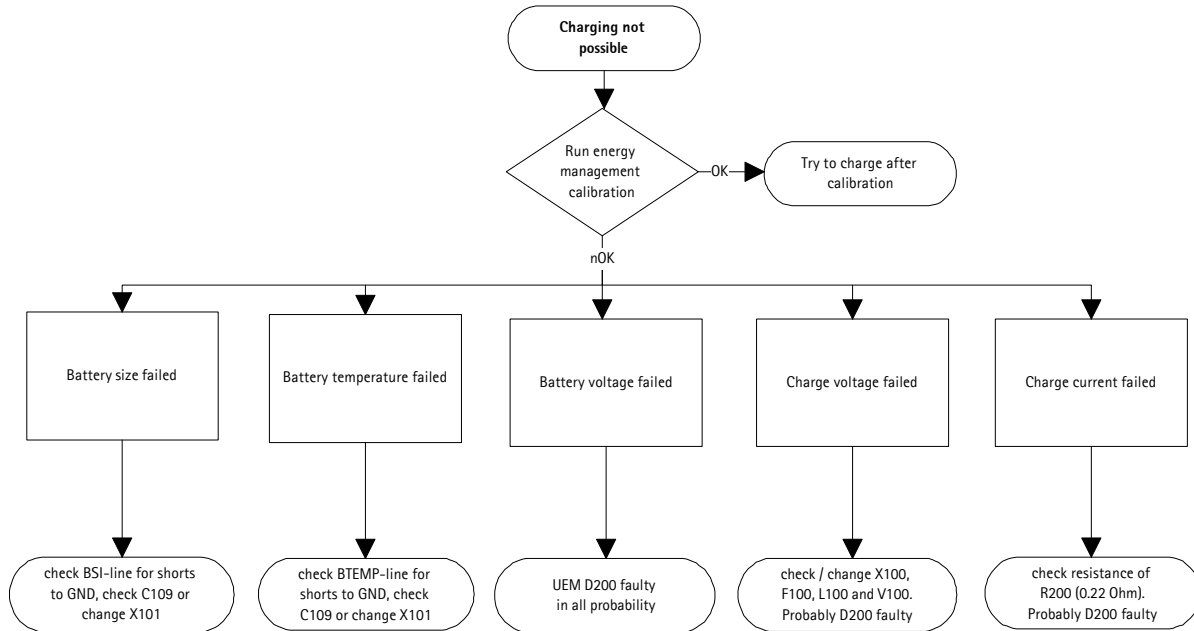
CHAPTER 6 CHARGING FAULTS

First thing you should do in case that charging of battery is not possible is to run energy management calibration. Note that calibration only works with JBV-1. In Service jig it is not possible because of missing bottom connector I009.

Also check whether charging is only from time to time not possible or if charging does not work permanently. In case that fault appears from time to time only, especially check spring contacts of bottom connector I009 and battery connector X101 if bent, soiled or corroded. Also make sure that contact pads for bottom connector on PCB are clean. If necessary clean PCB with an appropriate amount of alcohol. Do not use any scratching or rubbing tools!

To ensure function of the phone run energy management calibration whenever a part has been changed in the charging circuit!

I009, X101

- check mechanical appearance of battery connector and bottom connector, change parts if bent, soiled or corroded. also ensure that contact pads for bottom connector on PCB are clean.

F100

- check resistance of fuse. Must be 0Ω

V100

- check that V100 does not cause a short circuit to ground. Resistance of VCHAR-line to ground normally is $\sim 2.8k\Omega$

D200

- due to the missing possibility of rewriting IMEI and Simlockdata after changing UEM D200 it is not useful to change this part at the moment.

CHAPTER 7 USER INTERFACE FAULTS

Display faulty

- change displaymodule I004 to check if it is responsible for the fault
- check mechanical appearance of displayconnector X300, change part if necessary
- if fault persists check VIO 1.8VDC and VFLASH1 2.8VDC, both measurable at double capacitor C303 also check VOUT 8.1VDC at C301/302 which is generated by the displaymodule.
- If DC-voltages are ok but display does not work, probably UPP D400 faulty.
 Note that you have to make SW-update after changing UPP, otherwise the phone will not switch on!

Display- and keyboardillumination faulty

- check VBAT 4VDC at R304 and R307
- check that voltage at V300/301 pin 5/6 decreases from 3.5VDC to 3VDC if illumination gets active, check R305 (470Ω) or change V300/301 if necessary.
 It also is possible that UEM D200 faulty, but do not change this part since there is no possibility to rewrite phonedata.
- in case of faulty keyboardillumination also check mechanical appearance and solderings of board to board connector X303

Buzzer faulty

- ensure that fault is no result of too old phonesoftware. SW-version should be 4.04 or newer.
- if SW-update does not solve the problem, activate buzzer with Phoenix in menu "Maintenance/Testing/Audio Test". Check VBAT 4VDC and PWM-signal coming from UEM at buzzer, change buzzer if necessary
- it also is possible that UEM D200 is defect, but since there is no possibility to rewrite phonedata after reworking UEM you should not change this part.

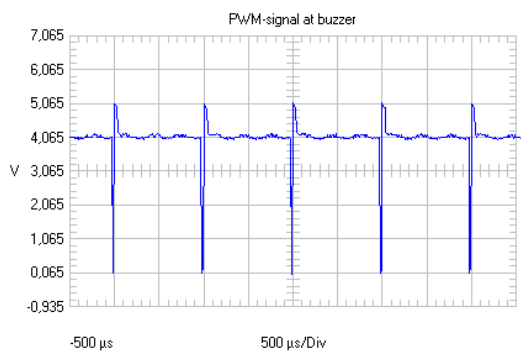

Name	= Active Channel 1
Date	= 21.01.02
Time	= 10:14:40
Y Scale	= 1 V/Div
Y At 50%	= 3.065 V
X Scale	= 500 μs/Div
X At 0%	= -500 μs
X Size	= 512 [512]
Maximum	= 5.100 V
Minimum	= 23.0 mV

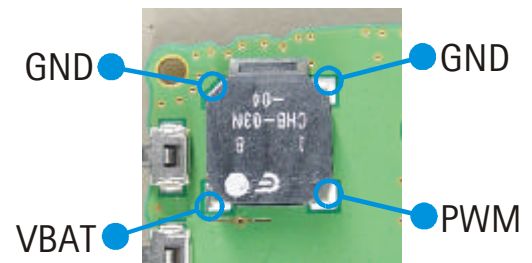

Vibramotor faulty

- as in case of faulty buzzer ensure that fault is not the result of too old phonesoftware, make SW-update if necessary
- check spring contacts of vibramotor if bent or soiled, change vibramotor if necessary
- if fault persists probably UEM D200 faulty. Do not change this part since there is no possibility to rewrite phonedata after changing UEM

Keyboard faulty

- if only a single key does not work displaymodule I004 is faulty in all probability. Exchange displaymodule and retest the phone
- in case that a whole row or column of keys (e.g. 2-5-8-0) does not work this also may be caused by a defect displaymodule, but it is more likely that EMI-filter Z301 interrupts the keyboardlines or UPP D400 is faulty. Also check solderings and mechanical appearance of board to board connector X303, change part if necessary.
 Note that you have to flash the phone after changing UPP, otherwise the phone will not switch on!

CHAPTER 8 NO SERVICE

In case that this fault occurs with your phone, the first thing you should do is to calibrate RX/TX-values of the phone. If for example TX-power is not measurable or too low, continue with the chapter below. If RX does not work, continue with the corresponding chapter on page 16. If RX and TX do not work check parts which are needed for both signalpaths (e.g. oscillators G650/660, Hagar N600 or UPP D400).

No or too low TX-power

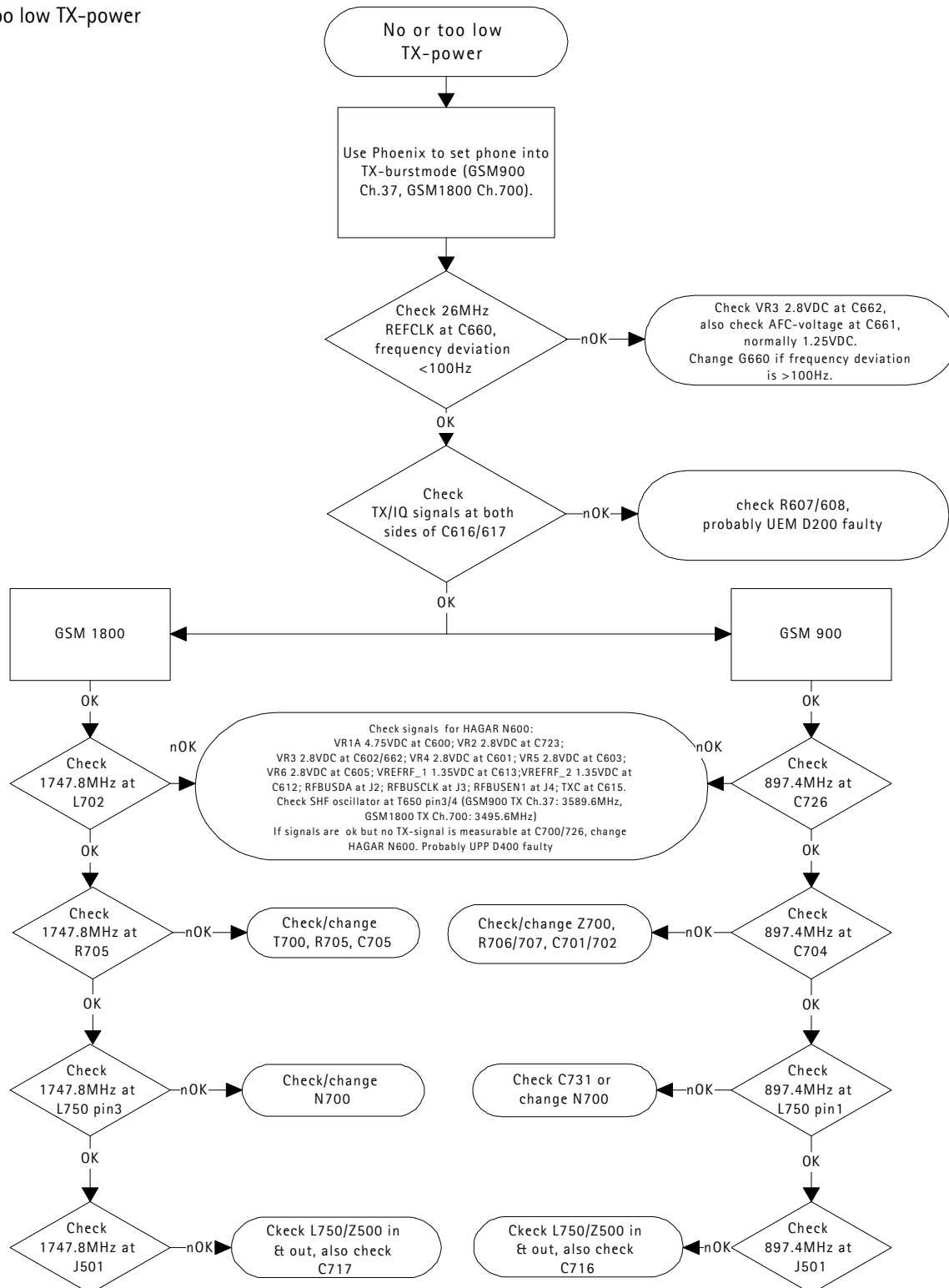

G660

- set phone with Phoenix on local mode
- check VR3 2.8VDC at C662. With only this voltage the oscillator must be able to work on a frequency of 26MHz, Otherwise you have to change G660. Check signal at C660:

AFC-voltage at C661 normally is 1.25VDC, but may vary between 0.05VDC and 2.5VDC.
 If frequency deviation of G660 is >100Hz it is necessary to change the oscillator!

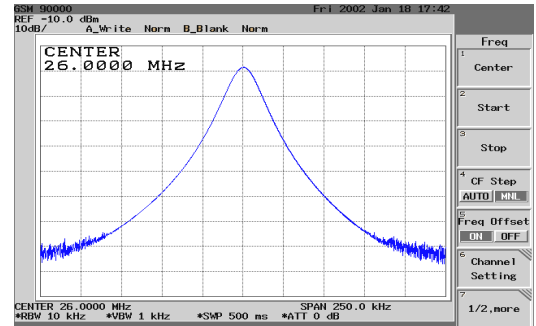

G650, C653

- to check if the SHF-oscillator G650 is working you have to activate with Phoenix e.g. TX-burstmode Ch.37. After that check signal (3589.6MHz) at T650 pin 3 and 4 as shown below:

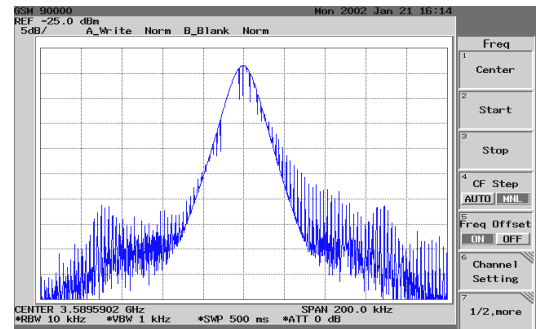

If no signal is measurable at T650 check VR7 2.6VDC at C650. If OK, set span of your analyser to e.g. 250MHz to check if the oscillator works on any other frequency as on the supposed. If this is the case check control voltage at C652 which normally is 2.1VDC on channel 37. In case of noise on the control voltage especially check C653 (tendency to leak).
 If the oscillator does not work at all, change G650 and retest the phone.

N700

- set phone with Phoenix to local mode and activate TX-burstmode Ch.37 (Ch.700 for GSM1800). Data in parenthesis are mentioned for GSM1800.
- check VBATTRF 3.9VDC on both sides of L703
- check incoming RF-signal of 897.4MHz at C731 (1747.8MHz at R705)
- check VTXBGSM 2.8Vpp at C720 (VTXBDCS 2.8Vpp at C714) and VPDGSM 1.3Vpp up to 2.5Vpp depending on TX-power-level at C719 (VPDDCS 1.2Vpp up to 2.1Vpp at C718):

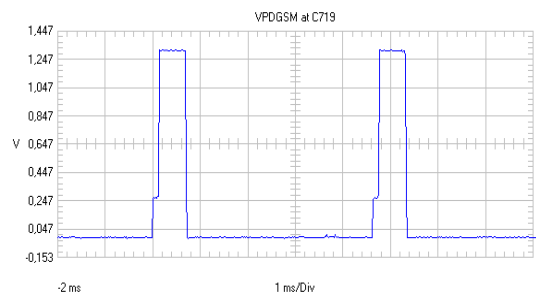
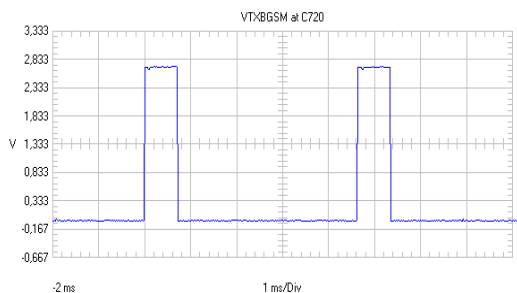

- check VTXLOGSM at R709. Signal/amplitude is the same as VTXBGSM, but it is only present in PA-free and -low mode.

If the above mentioned signals are ok but no or too low TX-power signal is measurable at L750 pin 1 (pin 3 in GSM1800), it is necessary to change the poweramplifier N700.

N600

- set phone with Phoenix to local mode and activate TX-burstmode Ch.37 (Ch.700 for GSM1800).
- check 26MHz reference clock at C660, refer to signal shown on page 14.
- check VR1A 4.75VDC at C600, VR2 2.8VDC at C723, VR3 2.8VDC at C662, VR4 2.8VDC at C601, VR5 2.8VDC at C603, VR6 2.8VDC at C605 and VR7 2.8VDC at C650
- check with an oscilloscope TXC at C615 (0.5Vpp – 2.1Vpp depending on TX-powerlevel), also check TX/IQ-signals at C616/617:

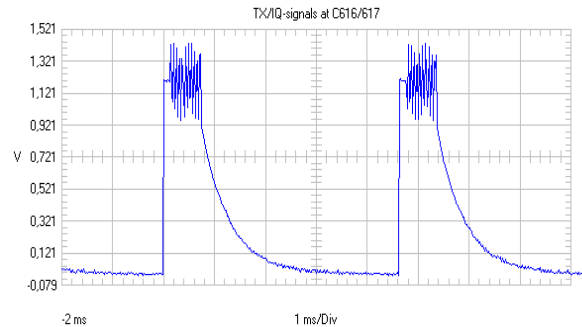
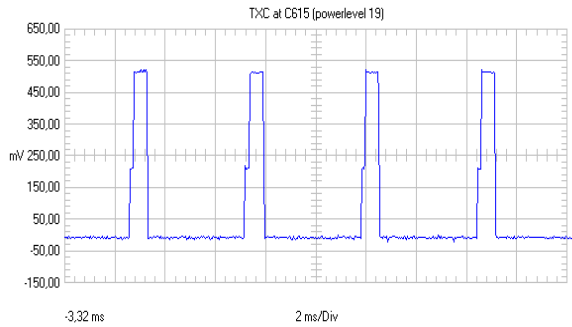

- check with an oscilloscope RFBUSDA at J2, RFBUSCLK at J3 and RFBUSEN1 at J4:

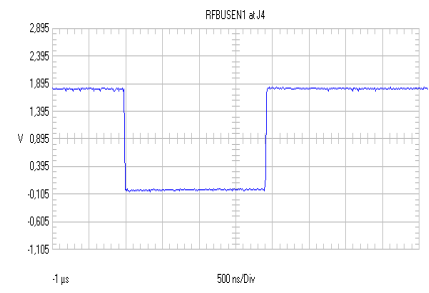
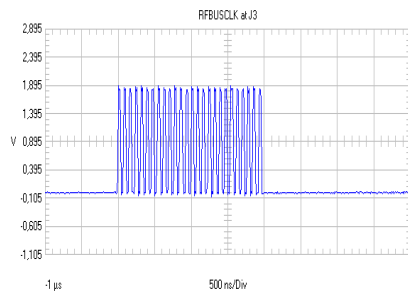
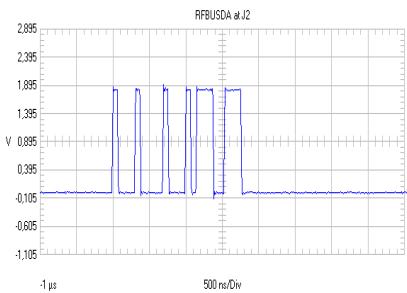

- check signal of SHF-oscillator at T650 pin 3 and 4 (3589.6MHz/Ch.37, 3495.6MHz/Ch.700). Refer to signal shown on previous page.

If these signals are ok but no TX-signal is measurable at C726 (C700 in GSM1800), you have to change Hagar N600. Unfortunately TXP and Hagar reset, which also are necessary for a working Hagar are not checkable because of missing testpoints. Change UPP D400 in case of doubt and retest the phone.

D200

- if it seems that UEM D200 is responsible for the fault because of missing TXC- or corrupted TX/IQ-signals, at this moment it makes no sense to change this part because of missing possibility to rewrite phonedata after changing UEM D200.

D400

- it has been seen that in some cases UPP D400 was responsible for "No Service"-faults. Unfortunately it is not possible to check some important signals because of missing testpoints (e.g. TXP, Hagar reset). Nevertheless you can check with an oscilloscope for activity on the RFBUS (J2/3/4). If already here a signal is missing and there is no short circuit to ground on these lines, you should change D400.

Note that it is necessary to reflash the phone after changing UPP. Otherwise the phone will not switch on.

CHAPTER 9 RX DOES NOT WORK

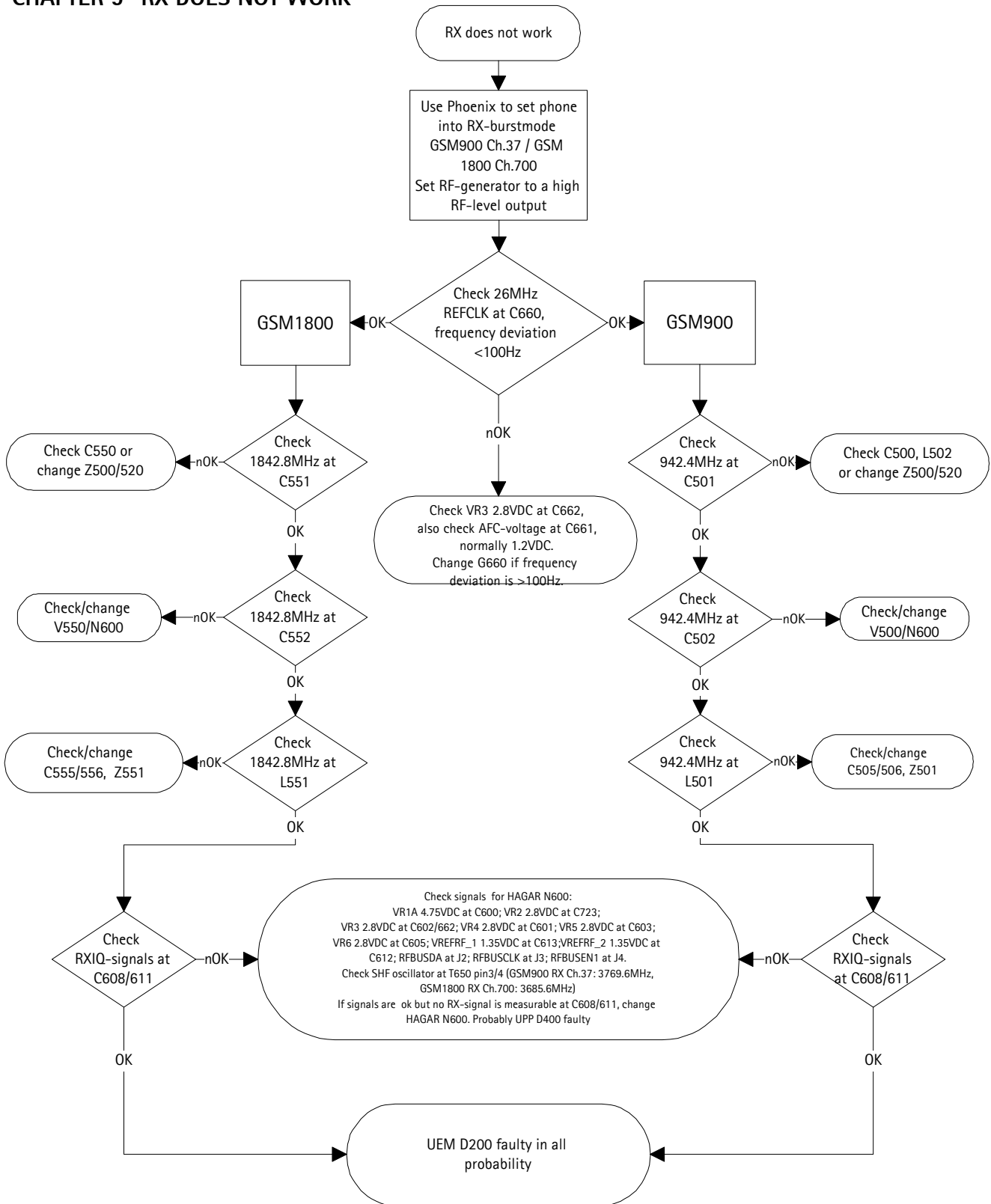

G660

- first thing to do as in case of TX-faults is to set phone with Phoenix to local mode, activate RX-burstmode Ch.37
- check VR3 2.8VDC at C662. With only this voltage the oscillator must be able to work on a frequency of 26MHz. Otherwise you have to change G660. Signal of G660 at C660 is shown on page 14. AFC-voltage at C661 normally is 1.25VDC, but may vary between 0.05VDC and 2.5VDC. If frequency deviation of G660 is >100Hz it is necessary to change the oscillator!

G650, C653

- to check if the SHF-oscillator G650 is working you have to activate RX-burstmode Ch.37. After that check signal (3769.6MHz) at T650 pin 3 and 4 as shown below:

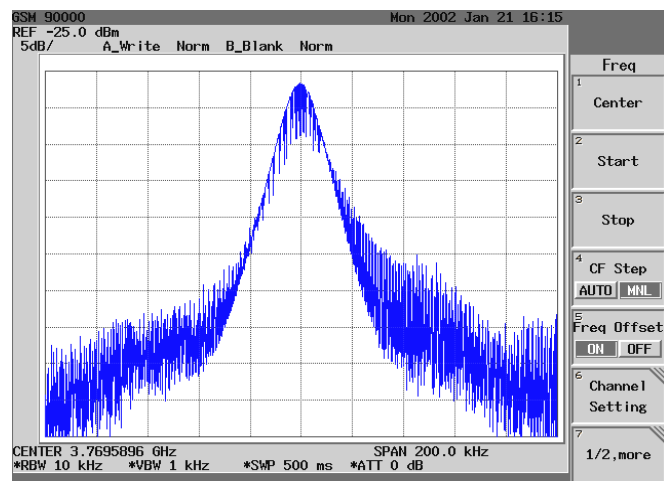

If no signal is measurable at T650 check VR7 2.6VDC at C650. If OK, set span of your analyser to e.g. 250MHz to check if the oscillator works on any other frequency as on the supposed. In case of that check control voltage at C652 which normally is 3VDC on channel 37. Especially check C653 (tendency to leak) in case of noise on the control voltage. In case that the oscillator does not work at all, change G650 and retest the phone.

N600

- set phone with Phoenix to local mode and activate RX-burstmode Ch.37 (Ch.700 for GSM1800), set RF-generator to high RF-level output, e.g. -40dBm
- check 26MHz reference clock at C660, refer to signal shown on page 14
- check incoming RX-signal of 942.4MHz at L501 (1842.8MHz at L551)
- check VR1A 4.75VDC at C600, VR2 2.8VDC at C723, VR3 2.8VDC at C662, VR4 2.8VDC at C601, VR5 2.8VDC at C603, VR6 2.8VDC at C605 and VR7 2.8VDC at C650
- check with an oscilloscope RFBUSDA at J2, RFBUSCLK at J3 and RFBUSEN1 at J4, refer to signals shown on page 15
- check signal of SHF-oscillator at T650 pin 3 and 4 (3769.6MHz/Ch.37, 3685.6MHz/Ch.700) as shown in the picture before.

If these signals are ok but no RX/IQ-signal is measurable at C608/611, you have to change Hagar N600. Probably UPP D400 is faulty. Change part in case of doubt and retest the phone.

CHANGE HISTORY

Originator	Status	Version	Date	Comment
TS Training Group	Draft	0.1	11.02.2002	First draft version for the repair group
TS Training Group	Approved	1.0	28.02.2002	First approved release